

Surface Track

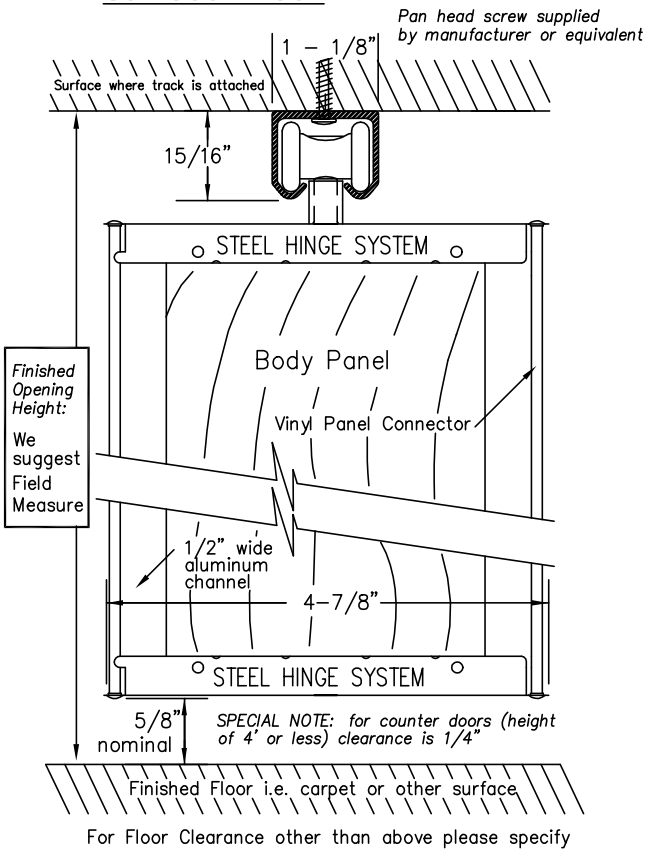

Recessed Track

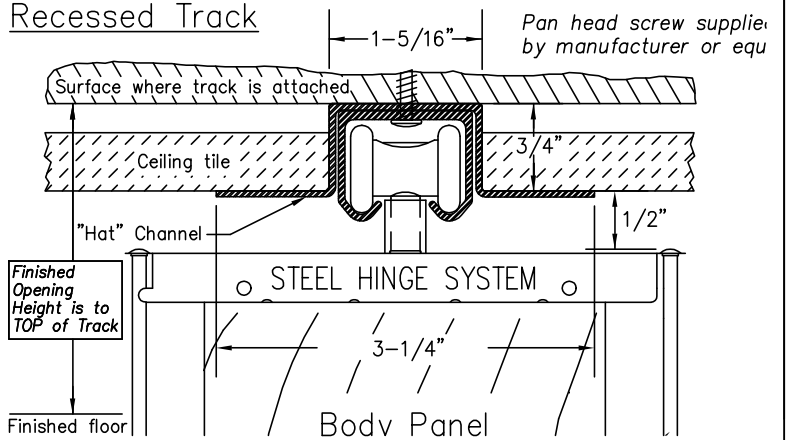

I-Beam Track

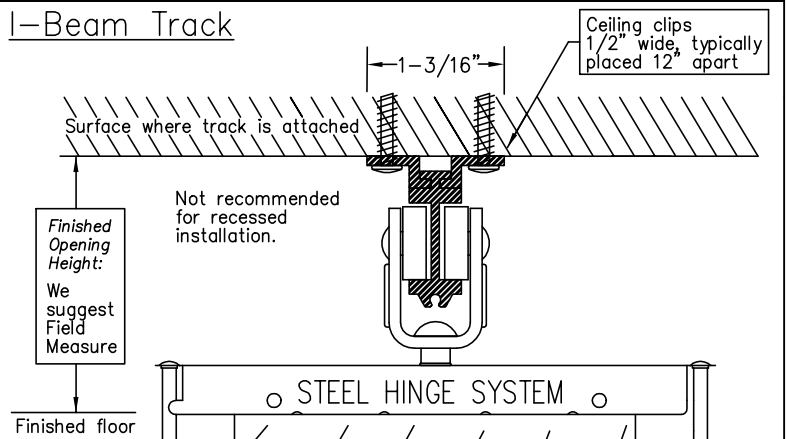

Door Types

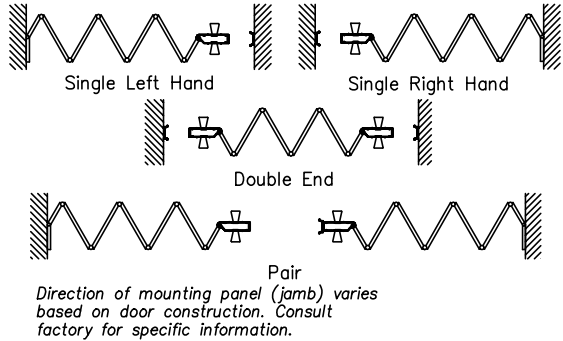

Lead Post, Jamb Mouldings & Handle

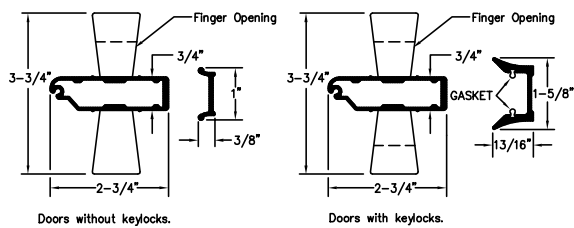

Sliding Jamb Option

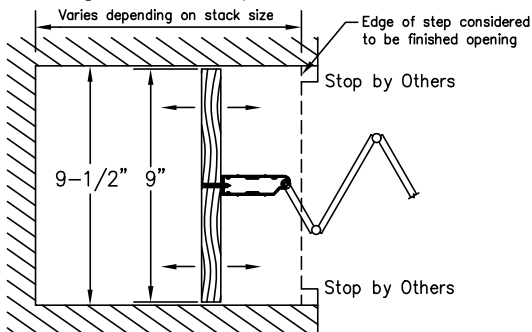

Mounting Panel

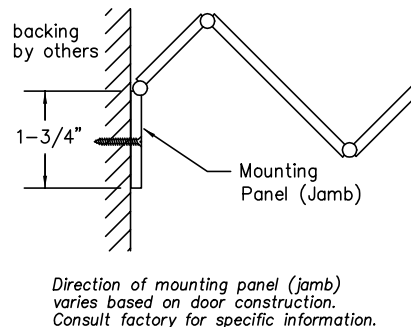

Multiple Meeting Option

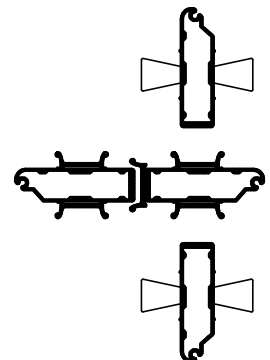

Stack Dimensions

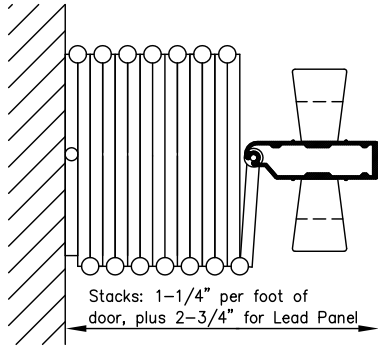

Intermediate Rolling Post

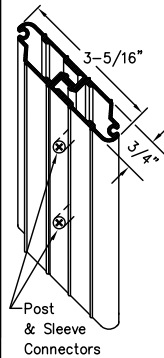

Privacy Latch



Keylock

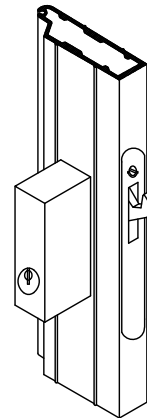

Single Cremone Bolt Keylock

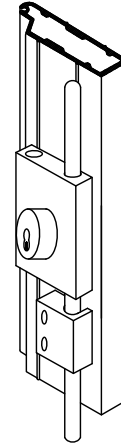

Double Cremone Bolt Key Lock

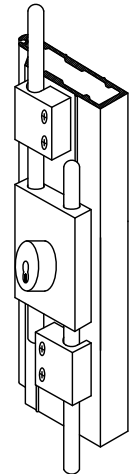

INFORMATION

Width	Custom made to any width										
Height	Custom made to 10' -1"										
Panels	Acrylic, natural hardwood or vinyl-lam										
Side Channel	Aluminum: White, Brown, Sand or Clear										
Panel Connector	Extruded Vinyl: White, Brown, Sand or Clear Coordinated with side channel										
Hinge System	Steel: Dark Bronze or Clear										
Wheels	Ball bearing nylon wheels on steel axles										
Track	Aluminum (straight or curvable): Dark Bronze or Clear										
Recessed Channel/ "Hat" Channel	Aluminum (straight only): White										
Lead, Intermediate and Jamb	Aluminum: White, Brown, Sand or Clear Coordinated with Side Channel										
Latch	Deadlatch with thumb turn two sides										
Header	Construction Details by Others										
Door Weight	<table border="0"> <tr> <td><u>Height</u></td> <td><u>Average Weight</u></td> </tr> <tr> <td>6'-8"</td> <td>10lbs. Per lineal foot</td> </tr> <tr> <td>8'-1"</td> <td>12lbs. Per lineal foot</td> </tr> <tr> <td>10'-1"</td> <td>15lbs. Per lineal foot</td> </tr> <tr> <td>12'-1"</td> <td>18lbs. Per lineal foot</td> </tr> </table>	<u>Height</u>	<u>Average Weight</u>	6'-8"	10lbs. Per lineal foot	8'-1"	12lbs. Per lineal foot	10'-1"	15lbs. Per lineal foot	12'-1"	18lbs. Per lineal foot
<u>Height</u>	<u>Average Weight</u>										
6'-8"	10lbs. Per lineal foot										
8'-1"	12lbs. Per lineal foot										
10'-1"	15lbs. Per lineal foot										
12'-1"	18lbs. Per lineal foot										

Catch/Lock Options

Magnet	Magnet with strike plate
Privacy Latch	Deadlatch with thumb turn one side
Springlatch	Springlatch with thumb turn two sides
Keylock 1 Side	Deadlatch with thumb turn one side, keylock one side
Keylock 2 Side	Deadlatch with keylock two sides
Single Cremone	Single cremone bolt with keylock
Double Cremone	Double cremone bolt with keylock
Footbolts	Locking or non locking
Other Keyed Options	Keyed alike, custom keyed, construction core Contact manufacture for more details

Job Name: _____
 Job Location: _____
 Supplier: _____

Architects Acceptance
By: _____
Date: _____

See Woodfold Accordion Door brochure for additional details

Qty.	Single/Pair	Single End/Double End	Left or Right Stack	Width X Height	Finish/Color	Comments

THESE SPECIFICATIONS ARE SUBJECT TO CHANGE WITHOUT NOTICE