

Swept-Wing Handles

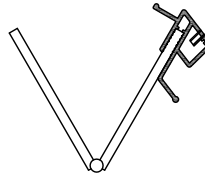

With integral magnet
With strike plate

Architects Acceptance

Job Name: _____
Job Location: _____
Supplier: _____

Stack Dimensions

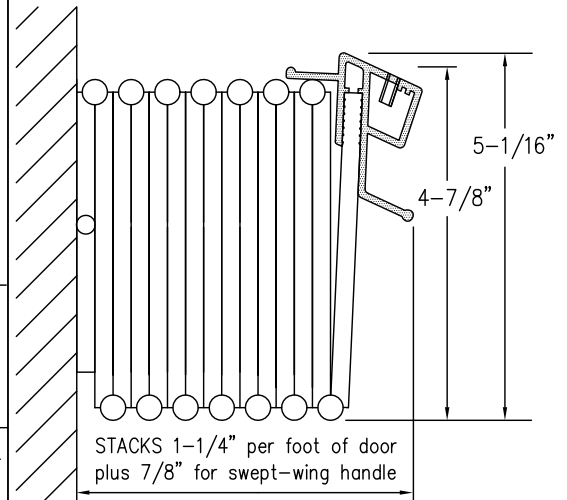

Mounting Panel

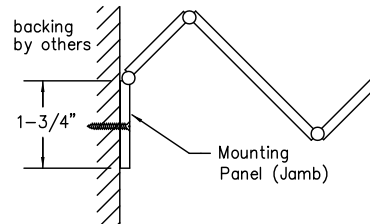

Direction of mounting panel (jamb) varies based on door construction. Consult factory for specific information.

Door Types

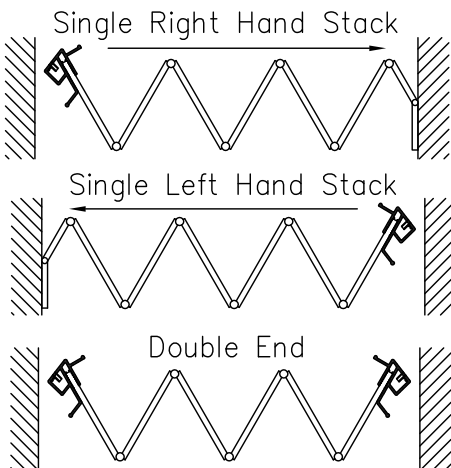

Door Types: Single or Double End only - no Pairs

INFORMATION

Width	Custom made to 8' - 0"
Height	Custom made to 8' - 1"
Panels	Natural hardwood or vinyl-lam on MDF core
Panel Connector	Extruded Vinyl: White, Brown or Sand
Hinge System	Steel: Dark Bronze or Clear Finish
Wheels	Nylon wheels on lexan axles
Track	Aluminum (straight only): Dark bronze or Clear
Swept Wing Handle	Rigid Vinyl: White, Brown or Sand Coordinated with panel connector
Catch	Magnet with strike plate
Header	Construction Detail by Others
Door Weight	<u>Height</u> <u>Average Weight</u>
	6'-8" 10lbs. Per lineal foot
	8'-1" 12lbs. Per lineal foot

See Woodfold Accordion Door brochure for details

Qty.	Single End/Double End	Left or Right Stack	Width X Height	Finish/Color	Comments